

Genetic architecture of a feeding adaptation: garter snake (*Thamnophis*) resistance to tetrodotoxin bearing prey

Chris R. Feldman, Edmund D. Brodie, Jr, Edmund D. Brodie III and Michael E. Pfrender

Proc. R. Soc. B 2010 **277**, 3317-3325 first published online 3 June 2010

doi: 10.1098/rspb.2010.0748

References

[This article cites 75 articles, 18 of which can be accessed free](#)

<http://rspb.royalsocietypublishing.org/content/277/1698/3317.full.html#ref-list-1>

Subject collections

Articles on similar topics can be found in the following collections

[molecular biology](#) (294 articles)

[ecology](#) (1919 articles)

[evolution](#) (2182 articles)

Email alerting service

Receive free email alerts when new articles cite this article - sign up in the box at the top right-hand corner of the article or click [here](#)

To subscribe to *Proc. R. Soc. B* go to: <http://rspb.royalsocietypublishing.org/subscriptions>

Genetic architecture of a feeding adaptation: garter snake (*Thamnophis*) resistance to tetrodotoxin bearing prey

Chris R. Feldman^{1,*}, Edmund D. Brodie Jr², Edmund D. Brodie III³
and Michael E. Pfrender⁴

¹Department of Natural Resources and Environmental Sciences, University of Nevada, Reno, NV 89557, USA

²Department of Biology, Utah State University, Logan, UT 84322, USA

³Department of Biology, University of Virginia, Charlottesville, VA 22904, USA

⁴Department of Biological Sciences, University of Notre Dame, Notre Dame, IN 46556, USA

Detailing the genetic basis of adaptive variation in natural populations is a first step towards understanding the process of adaptive evolution, yet few ecologically relevant traits have been characterized at the genetic level in wild populations. Traits that mediate coevolutionary interactions between species are ideal for studying adaptation because of the intensity of selection and the well-characterized ecological context. We have previously described the ecological context, evolutionary history and partial genetic basis of tetrodotoxin (TTX) resistance in garter snakes (*Thamnophis*). Derived mutations in a voltage-gated sodium channel gene ($Na_v1.4$) in three garter snake species are associated with resistance to TTX, the lethal neurotoxin found in their newt prey (*Taricha*). Here we evaluate the contribution of $Na_v1.4$ alleles to TTX resistance in two of those species from central coastal California. We measured the phenotypes (TTX resistance) and genotypes ($Na_v1.4$ and microsatellites) in a local sample of *Thamnophis atratus* and *Thamnophis sirtalis*. Allelic variation in $Na_v1.4$ explains 23 per cent of the variation in TTX resistance in *T. atratus* while variation in a haphazard sample of the genome (neutral microsatellite markers) shows no association with the phenotype. Similarly, allelic variation in $Na_v1.4$ correlates almost perfectly with TTX resistance in *T. sirtalis*, but neutral variation does not. These strong correlations suggest that $Na_v1.4$ is a major effect locus. The simple genetic architecture of TTX resistance in garter snakes may significantly impact the dynamics of phenotypic coevolution. Fixation of a few alleles of major effect in some garter snake populations may have led to the evolution of extreme phenotypes and an ‘escape’ from the arms race with newts.

Keywords: adaptation; gene of major effect; coevolution; *Thamnophis*; tetrodotoxin; sodium channel

1. INTRODUCTION

Since the early days of the modern synthesis, genetic studies combined with the analysis of phenotypic variation have been fundamental to our understanding of the process of adaptive evolution (Fisher 1958; Futuyma 1998; Orr 2005). In recent years, the study of adaptive variation has benefited from major gains in molecular genetic techniques and a growing body of work is now documenting the molecular basis of adaptation (e.g. Abzhanov *et al.* 2004; Albertson *et al.* 2005; Geffeney *et al.* 2005; Joron *et al.* 2006; Storz *et al.* 2007; Feldman *et al.* 2009). The results of these studies are rapidly increasing our understanding of the process and constraints of adaptive evolution. Nevertheless, a number of unresolved issues remain regarding the generality of the mechanisms suggested by empirical work (Orr 2005). Chief among these is whether adaptive evolution is typically driven by changes in many genes of minor effect (micromutational or polygenic model), or mutations in a few genes of major effect (macromutational or oligogenic model; Orr & Coyne 1992; Barton & Keightley 2002; Orr 2005).

Historically, it has been thought that adaptive evolution is primarily fuelled by changes in many genes with

minor effects (Fisher 1958; Lande 1983; Falconer & Mackay 1996). However, it has become increasingly clear that much of the variation in complex phenotypic traits is controlled by a small number of loci of major effect (e.g. Doebley & Stec 1991; Cohn & Tickle 1999; Krieger & Ross 2002; Abzhanov *et al.* 2004; Albertson *et al.* 2005; Hoekstra *et al.* 2006; Sutter *et al.* 2007; Storz *et al.* 2009), challenging the polygenic model of adaptive evolution (Orr & Coyne 1992; Orr 2005). While our view of the genetic architecture of adaptations is rapidly changing, both the polygenic and oligogenic viewpoints are certainly valid (Orr & Coyne 1992; Barton & Keightley 2002; Orr 2005). Each genetic model makes specific predictions about the tempo and mode of evolution, as well as the nature of selection (Fisher 1958; Lande 1983; Barton & Keightley 2002; Orr 2005). When the genetic architecture of a trait under selection is relatively simple, dramatic adaptation can occur rapidly through the fixation of a few beneficial mutations of large effect (Orr 2005; Barrett & Schluter 2008; e.g. Hawthorne & Via 2001; French-Constant *et al.* 2004; Colosimo *et al.* 2005; Hartley *et al.* 2006). Yet phenotypic evolution will proceed more slowly and through incremental steps if adaptive traits are controlled by large numbers of loci (Orr 2005). Polygenic

* Author for correspondence (ophis@cabnr.unr.edu).

adaptations will require many mutations, most of which are expected to be recessive and take longer to spread to fixation than dominant alleles (Kimura 1983). Furthermore, some loci might back-mutate and accumulate disadvantageous recombinants while waiting on adaptive mutations, whereas other loci may be constrained by epistatic interactions or pleiotropy. Thus, adaptive evolution should proceed gradually unless multiple loci can change in concert.

The genetic architecture of adaptations is also an important component of the dynamics of coevolution (Bohannan & Lenski 2000; Thompson 2005; Wade 2007; e.g. Yoshida *et al.* 2007). Cyclical coevolution wherein predator (exploiter) phenotypes continually 'chase' prey (victim) phenotypes are expected regardless of whether the genetic architecture underlying the traits is simple or complex (Sasaki 2000; Agrawal & Lively 2002, 2003; Kopp & Gavrillets 2006; Nuismer *et al.* 2007). However, when the traits that mediate the phenotypic interface of coevolution have a simple genetic basis, reciprocal selection can more easily fix adaptive alleles, leading to the evolution of extreme phenotypes in which the one species 'loses' the arm-race (Sasaki 2000; Kopp & Gavrillets 2006; Nuismer *et al.* 2007). Conversely, coevolutionary cycles are predicted to be more stable over time and more dynamic under a multilocus model because adaptive alleles in the predator rarely change in harmony, allowing the one species to stay 'ahead' in the arms race (Kopp & Gavrillets 2006; Nuismer *et al.* 2007).

The interaction between toxic newts (*Taricha*) and several resistant predatory garter snakes (*Thamnophis*) provides a model system for the study of adaptive variation and predator-prey coevolution (e.g. Brodie & Brodie 1999; Brodie *et al.* 2002a; Hanifin *et al.* 2008). This system is ideal because the traits that mediate coevolution are identified, geographically variable, and at least partly controlled by a well-studied gene family. Newts of the genus *Taricha* possess the neurotoxin tetrodotoxin (TTX; Mosher *et al.* 1964; Wakely *et al.* 1966; Brodie *et al.* 1974; Yotsu *et al.* 1990), which acts as a powerful chemical defence against vertebrate predators (Brodie 1968; Brodie *et al.* 1974). Tetrodotoxin binds selectively to the outer pore of voltage-gated sodium channels in nerves and muscles (Lipkind & Fozzard 2000; Hille 2001), blocking the movement of sodium ions (Na^+) across the cell membrane and halting the propagation of action potentials (Kao & Levinson 1986; Hille 2001). By arresting nerve impulses in muscle and nervous tissue, TTX causes immobilization, respiratory failure and often death (Brodie 1968; How *et al.* 2003; Isbister & Kiernan 2005). Despite the fact that TTX is one of the most powerful neurotoxins known (Medinsky & Klaassen 1996), three species of *Thamnophis* prey on sympatric newts (Brodie & Brodie 1990; Brodie *et al.* 2005) and have independently evolved high tolerance of TTX (Feldman *et al.* 2009).

The physiological and genetic mechanisms at least partially responsible for elevated TTX resistance involve slight alterations in the outer pore (P-loop) of the skeletal muscle sodium channel ($\text{Na}_v1.4$) that dramatically reduce the affinity of TTX to this protein (Geffeney *et al.* 2002, 2005; Feldman *et al.* 2009). Certain P-loop replacements in Na_v genes alter TTX ligation to sodium channels and these changes are thought to be at the root of physiological adaptation to TTX (Geffeney *et al.* 2005; Venkatesh *et al.*

2005; Jost *et al.* 2008; Feldman *et al.* 2009). Thus, Na_v loci probably constitute genes of major effect, yet we still lack a firm grasp on the contribution of individual alleles to TTX resistance. Although all populations of resistant garter snakes display some phenotypic variation, only a few exhibit the high degree of variance suggestive of multiple underlying Na_v genotypes. Here, we take advantage of striking variability in TTX resistance seen in *T. atratus* and *T. sirtalis* along the central coast of California. We focus on these two species at a local scale so that intraspecific comparisons occur between individuals with similar genetic backgrounds. We examine the relationship between allelic variation in $\text{Na}_v1.4$ and TTX resistance in these populations, and how this relationship bears on our understanding of adaptive evolution in garter snakes and the coevolutionary dynamics between newts and snakes.

2. MATERIAL AND METHODS

(a) Bioassays

We collected TTX resistance data from 76 *T. atratus* from Santa Lucia Preserve, Monterey Co. and 47 *T. sirtalis* from Gilroy, Santa Clara Co. and Santa Lucia Preserve, Monterey Co.

We measured TTX resistance using a highly repeatable and previously validated bioassay of whole organism performance (Brodie & Brodie 1990; Brodie *et al.* 2002b). We first established an individual's 'baseline speed' by racing it down a 4 m racetrack equipped with infrared sensors. We averaged the speed of two time trials to obtain an individual's baseline crawl speed. Following a day of rest (48 h between injections), we gave each snake an intra-peritoneal injection of a known, mass-adjusted dose of TTX (Sigma). Thirty minutes later we raced snakes again to determine 'post-injection speed.' We repeated this process, again resting snakes for a day (48 h between injections) then increasing the dose of TTX (0.5, 1, 2, 5 and 10 μg) and running snakes, up to five total sequential TTX tests per snake. We scored 'resistance' as the reduction of an individual's baseline sprint speed following an injection of TTX (post-injection speed/baseline speed). We calculated an individual's dose-response curve from the serial TTX injections using a simple linear regression (Ridenhour *et al.* 2004). From this regression model we estimated the '50 per cent dose,' the amount of TTX required to reduce the snake to 50 per cent of its baseline speed. Because TTX resistance is related to body size (Brodie & Brodie 1990; Ridenhour *et al.* 2004), we transformed doses into mass-adjusted mouse units (MAMU), the amount of TTX (mg) required to kill a 20 g mouse in 10 min (see Ridenhour *et al.* 2004).

Some of the *T. sirtalis* were so resistant to TTX that they were essentially unaffected by our standard injections. We administered additional TTX doses to a subset of these snakes and found they could still run above 50 per cent of their normal ability at over 200, 500 and 1000 MAMUs. We thus assigned a minimum 50 per cent estimate of 100 MAMUs to all unaffected *T. sirtalis* (based on the highest common dose given), recognizing that the actual measures of TTX resistance must be much higher. Because we assigned a threshold value of resistance, we could not estimate variance for samples including these individuals (i.e. *T. sirtalis* genotypes).

(b) Sequence data

We collected DNA sequence data from $\text{Na}_v1.4$ from each garter snake assayed for TTX resistance (*T. atratus* $n = 76$;

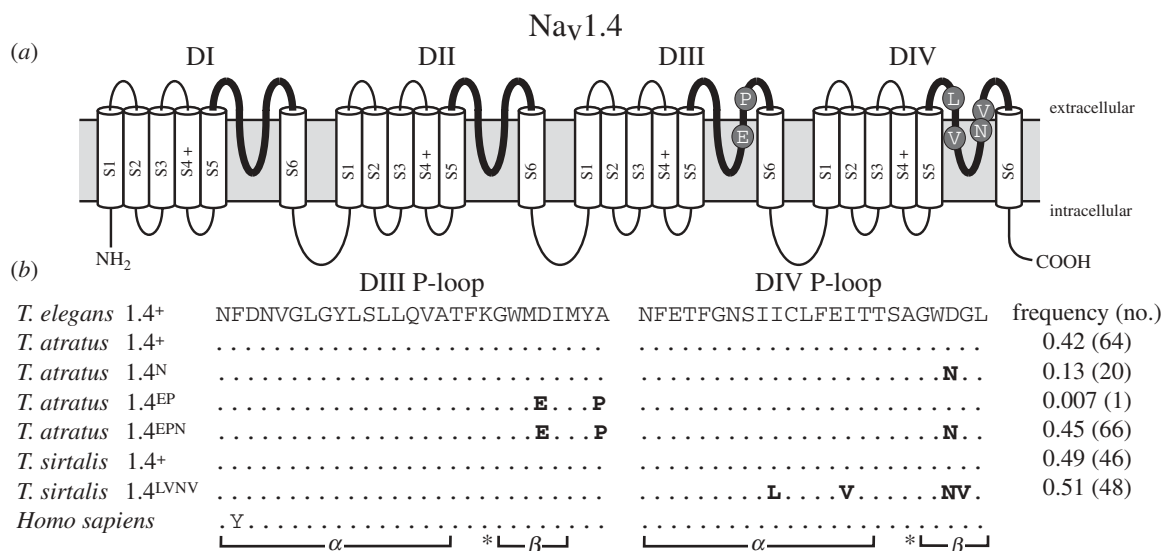

Figure 1. Structure of the α -subunit of the skeletal muscle sodium channel ($\text{Na}_v1.4$) and the functional variation that characterizes $\text{Na}_v1.4$ alleles in the garter snakes *Thamnophis atratus* and *T. sirtalis*. (a) The membrane bound $\text{Na}_v1.4$ protein is composed of four domains (DI–DIV) with six transmembrane segments (S1–S6) and linkers that connect segments. The four, polypeptide chains linking S5 to S6 (bold) are referred to as the pore loops (P-loops) because they form the cone-shaped outer pore of the channel, allowing the selective permeation of Na^+ ions vital for action potential generation and propagation. However, a number of P-loop residues bind strongly to the neurotoxin TTX, which occludes the pore and halts Na^+ movement. Derived P-loop replacements (grey circles) occur at critical residues in DIII and DIV that change the structure and electrostatic environment of the pore and alter TTX binding affinity (see text). (b) $\text{Na}_v1.4$ alleles identified in central California populations of *T. atratus* and *T. sirtalis* alongside the DIII and DIV P-loop amino acid sequences that characterize the alleles, and the frequencies at which these alleles were found. A TTX-sensitive *T. elegans* displaying the ancestral garter snake $\text{Na}_v1.4$ sequence (1.4⁺) is provided as a reference, and a human sequence is given for comparison (GenBank M81 758). Structures of the pore (*, selectivity filter; α , α -helix; β , β -strand) follow Lipkind & Fozzard (2000); invariant DI and DII P-loop sequences not shown.

T. sirtalis $n = 47$). The entire α -subunit of $\text{Na}_v1.4$ in garter snakes encodes 1875 residues (5658 bp) and shows high structural and amino acid homology, and conservation of intron/exon boundaries with mammalian $\text{Na}_v1.4$ (Feldman *et al.* 2009). However, we focused on variation in portions of the four domains (DI–DIV) that code for the outer pore (P-loops) because TTX interacts with residues of the outer pore (Lipkind & Fozzard 2000; Hille 2001) and changes at some of these sites in $\text{Na}_v1.4$ are thought to contribute to TTX resistance in snakes (Geffeney *et al.* 2005; Feldman *et al.* 2009) and pufferfish (Venkatesh *et al.* 2005; Jost *et al.* 2008; Maruta *et al.* 2008).

We isolated and purified genomic DNA from muscle or liver tissue with the DNeasy Tissue Kit (Qiagen, Inc.). We amplified the four P-loops of $\text{Na}_v1.4$ (figure 1) using primers we designed specifically to capture the regions between the S5 and S6 transmembrane segments (Feldman *et al.* 2009) that form the outer pore, yielding five amplicons of portions of the four domains (two from DIII) as follows: DI approximately 900bp (partial exon 8, all intron 8, partial exon 9); DII approximately 210bp (partial exon 13); DIIIa approximately 450bp (partial exon 19, partial intron 19) DIIIb approximately 800–1600bp (partial intron 19, all exon 20, all intron 20, partial exon 21); DIV approximately 450bp (partial exon 24). We cleaned amplified products using the ExcelsaPure PCR Purification Kit (Edge Biosystems) and used purified template in cycle-sequencing reactions with Big Dye 3.1 (Applied Biosystems, Inc.). Following an isopropanol/ethanol precipitation, we ran cycle-sequenced products on an ABI 3130 or ABI 3730 DNA Analyzer (Applied Biosystems, Inc.). We sequenced all samples in both directions.

We edited and aligned sequences in SEQUENCHER 4.2 (Gene Codes Corp.) and translated coding regions into amino acid sequences using MACCLADE 4.08 (Maddison & Maddison 2005). We deposited all sequences in GenBank (HM 365341–HM 365925).

We scored a $\text{Na}_v1.4$ sequence as a unique allele if it possessed amino acid replacements in or near the pore forming structures of the P-loops (pore α -helix, selectivity filter, β -strand; Lipkind & Fozzard 2000) that interact with TTX. Our notation for alleles includes the numerical designation of the sodium channel family member (i.e. 1.4) followed by a superscript of one letter amino acid abbreviations given in the order those derived allelic substitutions occur in the locus. This nomenclature reflects the molecular differences between the ancestral garter snake gene sequence (here termed 1.4⁺) and derived $\text{Na}_v1.4$ variants, rather than putative phenotypic effects or dominance attributes of alleles.

(c) Microsatellite data

To provide a rough estimate of background levels of variation in the garter snake genome to contrast against patterns in our candidate locus, we collected fragment data from putatively neutral loci for half our *T. atratus* sample ($n = 38$) and all our *T. sirtalis* sample ($n = 47$). We amplified 16 microsatellite markers developed for natricines (*Nerodia* and *Thamnophis*): NSU2, NSU3, NSU7, NSU8, NSU10 (Prosser *et al.* 1999), Ts2, Ts3, Ts4 (McCracken *et al.* 1999), 2Ts (Garner *et al.* 2002), Te1Ca2, Te1Ca18, Te1Ca29, Ts1Ca4 (Garner *et al.* 2004), TEO51B, TSO10, TSO42 (Manier & Arnold 2005). Microsatellites were end-labelled (forward primer) with one of four fluorescent tags (HEX, NED, 6FAM, PET), allowing us to multiplex amplified products

(2–5 markers per panel) and resolve genotypes on an ABI 3730 DNA Analyzer (using LIZ size standard). We re-genotyped samples with rare alleles, faint signal, or ambiguous peaks, and checked for error by re-genotyping a subset of all samples. We scored alleles with GENEMARKER v1.85 (SoftGenetics).

(d) Genotypic analyses

We calculated numbers of alleles (N_a), frequencies, and observed (H_o) and expected (H_e) heterozygosities for each locus in GENALEX v6.2 (Peakall & Smouse 2006). We tested for deviations from Hardy–Weinberg equilibrium (HWE) in each locus using the exact test in GENEPOP v4 (Raymond & Rousset 1995; Rousset 2008). We also assessed linkage disequilibrium (LD) among loci using the likelihood ratio test in GENEPOP. We estimated p -values for HWE and LD tests in GENEPOP with the Markov chain method, running 100 batches with 1000 iterations per batch, then adjusted p -values using the sequential Bonferroni correction (Rice 1989). Finally, we assessed the degree of population structure within our *T. atratus* and *T. sirtalis* data by calculating the inbreeding coefficient (F_{IS}) in GENALEX.

(e) Phenotype–genotype matching

We assigned each phenotype to its respective genotype for each locus and then determined the statistical association between genotypes (allelic variation in N_a ,1.4 or in microsatellites) and phenotypes (variation in TTX resistance) with a single factor analysis of variance (ANOVA) using restricted maximum likelihood in SAS v9.2 (SAS Institute). This method also yields an estimate of the percentage of variance explained (PVE) by the genotype, that is, the proportion of the total trait variance attributed to the genotype (e.g. Hoekstra *et al.* 2006). We then tested for overall differences in TTX resistance between N_a ,1.4 genotypes with post hoc tests to assess the significance of pairwise differences between N_a ,1.4 genotypes; we used t -tests of the least squares means from the single factor ANOVA to assess differences among *T. atratus* genotypes, and Chi-square tests of the Wilcoxon scores from a Kruskal–Wallis one-way ANOVA to assess differences among *T. sirtalis* genotypes. We used the non-parametric Kruskal–Wallis test for *T. sirtalis* to accommodate the truncated values of resistant snakes.

We qualitatively note apparent patterns of allelic dominance in N_a ,1.4 but did not formally evaluate dominance here because we could not estimate phenotypic variances around some *T. sirtalis* genotypes (see above) and because we did not identify any fully heterozygous *T. atratus* (see results).

3. RESULTS AND DISCUSSION

(a) Variation in TTX resistance

Thamnophis atratus and *T. sirtalis* from central coastal California possess extensive variation in TTX resistance. For example, the amount of TTX required to slow *T. atratus* to 50 per cent of their normal crawl speed ranged from 2 to 100 MAMUs, likewise, 50 per cent TTX dosages in *T. sirtalis* ranged from 6 to more than 100 MAMUs. In fact, the range of phenotypes observed here is equivalent to the range of TTX resistance seen across the entire *Thamnophis* clade, with some *T. atratus* and *T. sirtalis* possessing ancestral, low levels of TTX resistance (e.g. 2–5 MAMUs; Motychak *et al.* 1999; Feldman *et al.* 2009) and others exhibiting some of the

most dramatic resistance ever recorded (e.g. more than 100 MAMUs; Brodie *et al.* 2002a; Feldman *et al.* 2009).

(b) Variation in N_a ,1.4 and neutral markers

We found four N_a ,1.4 alleles in our central coastal population of *T. atratus* (1.4^+ , 1.4^{EPN} , 1.4^{EP} , 1.4^N ; figure 1). The first, 1.4^+ , is the same TTX-sensitive N_a ,1.4 allele ('wild-type') found across the garter snake phylogeny (Feldman *et al.* 2009). The three derived *T. atratus* alleles can be distinguished from 1.4^+ as follows: 1.4^{EPN} contains a D1277E in the DIII β -strand, an A1281P C-terminal to the DIII β -strand, and a D1568N in the DIV β -strand; 1.4^{EP} holds the two DIII changes, D1277E and A1281P; 1.4^N possesses only the DIV replacement, D1568N. The four alleles are distributed among only four genotypes in this *T. atratus* population (figure 2).

Though N_a ,1.4 in this population of *T. atratus* displays similar allelic richness to the neutral markers, actual heterozygosity in N_a ,1.4 is lower than all but one variable microsatellite (table 2). Furthermore, N_a ,1.4 is severely out of HWE, consistent with the premise that this gene is under strong natural selection. Only one microsatellite is out of HWE despite the fact that some non-random mating is evident ($F_{IS} = 0.186$), but this marker is not associated with N_a ,1.4 (all markers statistically unlinked; data not shown) or the phenotype (table 2).

We found only two N_a ,1.4 alleles in central coastal *T. sirtalis* (1.4^+ , 1.4^{LVNV} ; figure 1). As with *T. atratus*, some *T. sirtalis* possess the same functional allele that appears to represent the ancestral garter snake N_a ,1.4 sequence (Feldman *et al.* 2009). The derived *T. sirtalis* allele differs from this putative ancestor through four mutations in the P-loop of DIV; 1.4^{LVNV} is characterized by an I1555L and I1561V in the α -helix and a D1568N and G1569V in the β -strand. We found the two *T. sirtalis* N_a ,1.4 alleles in all three possible genotypic combinations (figure 2).

As in *T. atratus*, N_a ,1.4 in sympatric *T. sirtalis* also exhibits a similar number of alleles as neutral loci, but generally displays lower overall heterozygosity (table 2). The locus is also out of HWE, however, so are four microsatellites (table 2). It is not clear if such widespread disequilibrium is the hallmark of selection in this genome (all markers statistically unlinked; data not shown), or simply the fact that our sample of *T. sirtalis* does not represent a single panmictic unit, though F_{IS} is negligible (0.086), suggesting little structure attributable to non-random breeding.

(c) Relationship between variation in N_a ,1.4 and TTX resistance

We identified five N_a ,1.4 alleles (four derived) in these garter snakes. Three of the N_a ,1.4 alleles have been identified and detailed previously (Geffeney *et al.* 2005; Feldman *et al.* 2009), and the two *T. sirtalis* alleles have been functionally expressed (Geffeney *et al.* 2005). Most of the P-loop replacements that characterize the derived N_a ,1.4 alleles have been documented to reduce the binding affinity of TTX to sodium channels at the molecular level (Terlau *et al.* 1991; Pérez-García *et al.* 1996; Chen *et al.* 1997; Penzotti *et al.* 1998; Choudhary *et al.* 2003; Geffeney *et al.* 2005; Jost *et al.* 2008; Maruta *et al.* 2008), and a number are coincident with those seen in

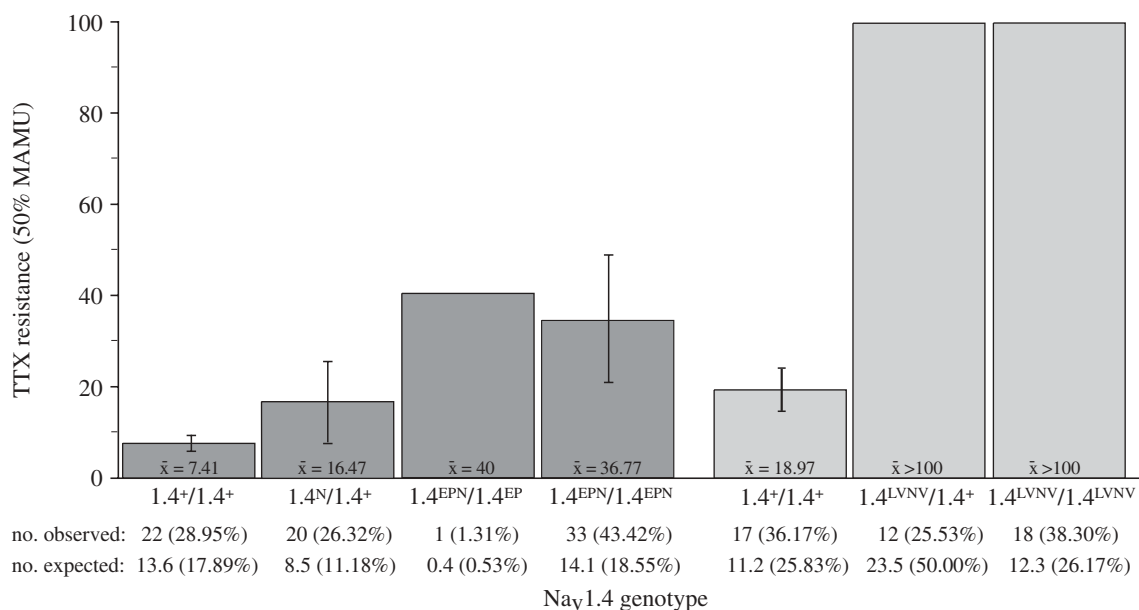

Figure 2. TTX resistance in *T. atratus* (dark grey) and *T. sirtalis* (light grey) allocated by Na_v1.4 genotype. For each genotype, mean TTX resistance, standard deviation (error bars), and observed versus expected genotypes are given. Note that some *T. atratus* genotypes were not detected in our sample (expected proportions do not total 100%). Due to the heightened resistance of *T. sirtalis* with derived Na_v1.4 alleles, we were forced to assign a minimum threshold value of TTX resistance and could not estimate phenotypic variance for these individuals (see text).

TTX-bearing pufferfish (Venkatesh *et al.* 2005; Jost *et al.* 2008; Maruta *et al.* 2008). Individual P-loop substitutions modulate TTX ligation by changing the structure and molecular environment of the channel's outer pore, reducing the number and strength of chemical bonds as well as dampening steric attraction between TTX and the outer pore (e.g. Tikhonov & Zhorov 2005; Scheib *et al.* 2006). For example, the D1568N replacement observed in both snake species occurs at a site known to play a major role in TTX ligation (Terlau *et al.* 1991; Pérez-García *et al.* 1996; Chen *et al.* 1997; Penzotti *et al.* 1998; Choudhary *et al.* 2003). This specific amino acid substitution has been shown to increase TTX resistance 30–40-fold in rat Na_v1.4 (Penzotti *et al.* 1998; Choudhary *et al.* 2003), probably because the hydrogen bond normally formed between TTX and D1568 (Chen *et al.* 1997; Choudhary *et al.* 2003; Scheib *et al.* 2006) is neutralized by uncharged N, and because the larger functional group of N alters the volume of the outer pore. Nevertheless, a direct relationship between allelic variation in Na_v1.4 and TTX resistance at the organismal level has yet to be established.

Partitioning *T. atratus* phenotypes into their respective Na_v1.4 genotypes reveals obvious phenotypic differences between the groups (table 1; figure 2). Snakes homozygous for the ancestral Na_v1.4 allele exhibit the lowest TTX resistance (=7.41, s.d. = 3.99) while the next lowest group is composed of snakes heterozygous for 1.4^N and 1.4⁺ (=16.47, s.d. 18.08). These two genotypes display considerably lower TTX resistance (t -value = -5.06, $p < 0.0001$; t -value = -3.77, $p = 0.0003$) than snakes with the 1.4^{EPN} allele (=47.84, SD 39.80). Whether the effects of the individual amino acid substitutions is additive remains to be determined. Nevertheless, the association between Na_v1.4 polymorphism and TTX resistance is significant in *T. atratus* ($F_{3,78} = 6.764$, $p < 0.0004$), and 23.4 per cent of the phenotype is explained by the Na_v1.4

Table 1. Differences in TTX resistance between Na_v1.4 genotypes in central California populations of *T. atratus* and *T. sirtalis*. Statistically significant differences between genotypes in italic.

taxon genotypes compared	t -value ^a	χ^2 -value ^b	p -value
<i>T. atratus</i>			
1.4 ⁺ /1.4 ⁺ versus 1.4 ^N /1.4 ⁺	-1.22	—	0.2269
1.4 ⁺ /1.4 ⁺ versus 1.4 ^{EPN} /1.4 ^{EP}	-1.32	—	0.1895
1.4 ⁺ /1.4 ⁺ versus 1.4 ^{EPN} /1.4 ^{EPN}	-4.11	—	<i>0.0001</i>
1.4 ^N /1.4 ⁺ versus 1.4 ^{EPN} /1.4 ^{EP}	-0.95	—	0.3431
1.4 ^N /1.4 ⁺ versus 1.4 ^{EPN} /1.4 ^{EPN}	-2.67	—	<i>0.0094</i>
1.4 ^{EPN} /1.4 ^{EP} versus 1.4 ^{EPN} /1.4 ^{EPN}	0.22	—	0.8319
<i>T. sirtalis</i>			
1.4 ⁺ /1.4 ⁺ versus 1.4 ^{LVNV} /1.4 ⁺	—	21.98	<i><0.0001</i>
1.4 ⁺ /1.4 ⁺ versus 1.4 ^{LVNV} /1.4 ^{LVNV}	—	29.53	<i><0.0001</i>
1.4 ^{LVNV} /1.4 ⁺ versus 1.4 ^{LVNV} /1.4 ^{LVNV}	—	0	1

^aDifferences between *T. atratus* assessed with t -tests of the least squares means from a single factor ANOVA.

^bDifferences between *T. sirtalis* assessed with Chi-square tests of the Wilcoxon Scores (ranked sums) from Kruskal–Wallis one-way ANOVA.

genotype (table 2). This pattern of association contrasts that seen among neutral loci, which show no relationship with TTX resistance (table 2).

Matching *T. sirtalis* phenotypes to their respective Na_v1.4 genotypes also reveals dramatic differences

Table 2. Genetic variation in $Na_v1.4$ and 16 microsatellite markers in central California *T. atratus* and *T. sirtalis* as measured in number of alleles (N_a) and observed heterozygosities (H_o), along with tests for Hardy–Weinberg equilibrium (HWE) and relationships between genotype and phenotype (using a single factor ANOVA). Loci that did not produce reliable amplicons denoted as not applicable (N/A); loci that were monomorphic denoted with dash.

locus	<i>T. atratus</i>						<i>T. sirtalis</i>					
	HWE			ANOVA			HWE			ANOVA		
	N_a	H_o	χ^2 -value	<i>p</i> -value ^a	<i>F</i> -value	<i>p</i> -value ^a	N_a	H_o	χ^2 -value	<i>p</i> -value ^a	<i>F</i> -value	<i>p</i> -value ^a
$Na_v1.4$	4	0.21	82.34	<0.0001	6.764	0.0004	2	0.26	19.794	0.0005	1330.820	<0.0001
TeCa29	5	0.84	9.975	0.443	0.9925	0.970	2	0.33	1.920	0.1659	2.117	0.1524
TeCa18	11	0.33	109.413	<0.0001	1.563	0.3259	7	0.65	4.028	0.4022	0.755	0.6693
Te1Ca2	5	0.57	11.081	0.351	0.685	0.7083	3	0.41	3.544	0.4713	0.767	0.5528
TEO51B	8	0.67	32.657	0.249	0.627	0.7652	12	0.89	127.942	<0.0001	1.795	0.0830
NSU10	6	0.61	10.548	0.784	0.940	0.5293	9	0.79	10.746	0.0296	0.681	0.7835
NSU8	1	0	—	—	—	—	2	0.06	0.050	0.8231	1.509	0.2255
NSU7	3	0.84	9.070	0.028	0.342	0.7953	5	0.45	8.267	0.0826	0.922	0.5081
NSU3	10	0.79	41.846	0.606	0.433	0.8821	10	0.71	15.141	0.0044	1.210	0.3145
NSU2	6	0.84	6.531	0.969	5.944	0.0301	1	0	—	—	—	—
Ts2	10	0.56	53.122	0.190	0.665	0.7362	N/A	N/A	N/A	N/A	N/A	N/A
Ts3	2	0.37	0.626	0.429	0.166	0.8488	2	0.21	0.094	0.7592	0.783	0.4635
Ts4	4	0.33	8.198	0.224	0.759	0.6164	17	0.65	280.051	<0.0001	1.121	0.3981
Ts1Ca4	5	0.63	7.310	0.696	0.726	0.6961	9	0.97	148.111	<0.0001	2.035	0.1000
TSO10	6	0.44	17.776	0.275	2.025	0.1807	4	0.75	2.2231	0.6948	1.141	0.3579
TSO42	N/A	N/A	N/A	N/A	N/A	N/A	3		16.649	0.0023	0.692	0.5624
2Ts	2	0.06	0.016	0.901	0.795	0.3867	N/A	N/A	N/A	N/A	N/A	N/A

^a*p*-values in italic remain significant following Bonferroni correction.

among the genotypes (table 1; figure 2). Snakes homozygous for 1.4^+ show moderate levels of TTX resistance (=18.97, s.d. = 8.58) while those heterozygous for 1.4^{LVNV} and 1.4^+ or homozygous for 1.4^{LVNV} display exceedingly high resistance (>100.00; >100.00). Snakes with these latter two genotypes are significantly less affected by TTX than those homozygous for 1.4^+ (χ^2 -value = 21.98, $p < 0.0001$; χ^2 -value = 29.53, $p < 0.0001$), but indistinguishable from one another, at least as quantified here (χ^2 -value = 0, $p = 1$). Thus, the derived 1.4^{LVNV} allele appears to exhibit complete dominance. However, our capacity to detect dominance is limited by our inability to estimate the phenotype variance around these two genotypes (see §2). At the molecular genetic level, it seems reasonable to expect that heterozygotes would be less resistant to TTX because presumably half of the skeletal muscle sodium channels in these snakes should be translated from the 1.4^+ allele. Yet at the organismal level, *T. sirtalis* heterozygous or homozygous for 1.4^{LVNV} appear so immune to TTX that these genotypes may be functionally equivalent. The relationship between variation in $Na_v1.4$ and TTX resistance in these *T. sirtalis* populations is strong ($F_{2,44} = 1330.820$, $p < 0.0001$; we cannot consider the PVE of 98% from our ANOVA reliable given our truncated dataset). Conversely, our microsatellite markers, which provide a rough measure of background variation in the garter snake genome, show no association with the phenotype (table 2), supporting the conclusion that the robust link between $Na_v1.4$ genotype and phenotype is not an artefact of hidden population structure.

(d) Adaptation and gene family evolution

We show that $Na_v1.4$ is clearly a large effect locus, explaining 23 per cent of TTX resistance in *T. atratus*

and correlating completely with qualitative differences in TTX resistance in *T. sirtalis*. Nevertheless, allelic variation in $Na_v1.4$ cannot solely account for whole animal resistance in garter snakes. First, the proportion of the phenotype explained by the genotype in *T. atratus* suggests the contribution of additional loci or molecular mechanisms. Second, the levels of TTX resistance displayed by *T. sirtalis* that are homozygous for the ancestral $Na_v1.4$ allele (1.4^+) are higher than *T. atratus* and other garter snakes with this same non-resistant genotype (Feldman *et al.* 2009). Third, $Na_v1.4$ expression is confined to skeletal muscle tissue (Trimmer *et al.* 1989, 1990; Goldin 2001), yet the central nervous system and some peripheral nerves are natively sensitive to TTX (Goldin 2002). It seems evident that these tissues must also be defended against TTX to produce a fully resistant organism.

In mammals, nine different Na_v genes are functionally expressed in specific tissues with excitable cells (Plummer & Meisler 1999; Goldin 2001; Hille 2001). A third of these ($Na_v1.5$, $Na_v1.8$, $Na_v1.9$) are natively insensitive to TTX (Goldin 2002), while the remaining sodium channels ($Na_v1.1$, $Na_v1.2$, $Na_v1.3$, $Na_v1.4$, $Na_v1.6$, $Na_v1.7$) are highly sensitive to the toxin (Goldin 2002). Modification of other TTX-sensitive Na_v loci may have encountered adaptive mutations similar to those in the derived $Na_v1.4$ alleles. Because even single mutations can dramatically alter TTX binding affinity (e.g. Noda *et al.* 1989; Terlau *et al.* 1991; Geffeney *et al.* 2005; Tikhonov & Zhorov 2005; Venkatesh *et al.* 2005; Du *et al.* 2009), only slight modification of central and peripheral nerve Na_v genes may be required. Indeed, parallel changes have occurred across Na_v paralogues in TTX-bearing pufferfish (Jost *et al.* 2008). Interestingly, in vertebrates most Na_v paralogues are physically close to their nearest relatives (Plummer & Meisler 1999; Goldin 2002; Novak *et al.* 2006), and in mammals, seven of the nine

genes are regionally clustered within two chromosomes (Plummer & Meisler 1999; Goldin 2002). Thus, coincident P-loop changes in separate sodium channel genes might immediately become linked. If recombination rates are low, selection could easily fix such linkage groups in populations before recombination breaks apart adaptive allelic combinations.

We suspect that convergent gene family evolution (e.g. Jost *et al.* 2008; Storz *et al.* 2009) explains whole animal TTX resistance in garter snakes and suggest that both *T. atratus* and *T. sirtalis* demonstrate the extremes of this scenario. In the case of *T. sirtalis*, derived Na_v variants may have become (or remain) linked, forming a coadapted gene complex that produces an extreme phenotype. In *T. atratus*, on the other hand, recombination may have disassociated the linkages between TTX resistant alleles at separate Na_v loci. Some *T. atratus* would still inherit this suite of adaptive variation and possess the 'Na_v supergene' that produces acute resistance. Others would possess varying degrees of mismatch between resistant Na_v genes and express corresponding levels of TTX resistance. Alternatively, species differences in resistance variation might exist because of differences in the age of the ecological interaction with newts or of the mutations themselves. Identification and characterization of the P-loops in all TTX-sensitive sodium channels in *Thamnophis* should eventually provide a complete picture of the molecular mechanisms responsible for elevated TTX resistance.

(e) Simple genetic architecture and coevolution

The molecular basis of adaptive TTX resistance in *Thamnophis* appears relatively simple, probably involving a few replacements in a handful of genes. Simple genetic architecture underlying the traits that mediate coevolution should allow for a rapid back-and-forth evolutionary arms race, but also potential 'escape' from the arms race by the predator (Sasaki 2000; Kopp & Gavrilets 2006; Nuismer *et al.* 2007). Though we only have a handle on the genetics underlying the predatory counter adaptation, both of these predictions appear to have been met. Although coevolution between toxic newts and predatory garter snakes has deep roots, and probably extends beyond the diversification of many contemporary lineages (Feldman *et al.* 2009), a number of *T. sirtalis* and *T. granulosa* populations in the Pacific Northwest seem to have initiated an arms race only recently, probably during the Late Pleistocene (Ridenhour *et al.* 2007). A range-wide survey of trait matching between *T. sirtalis* and *Taricha* showed that one-third of western *T. sirtalis* populations possess such acute TTX resistance that they are essentially 'winning' the arms race (Hanifin *et al.* 2008). Characterization of additional Na_v loci in *Thamnophis* and continued phenotype–genotype matching at the population level will help determine whether the evolution of a Na_v supergene in garter snakes frequently creates an insurmountable counter measure to which newts cannot respond, or whether recombination and gene flow consistently decouple adaptive alleles and keep newts competitive in this arms race.

All research was conducted under approval of Utah State University IACUC (Protocol no. 1008). Snakes injected with small doses of TTX fully recover after several hours (Brodie *et al.* 2002b), and as a sodium channel blocker,

TTX impedes pain reception (Lai *et al.* 2003). At the completion of the study, all specimens were humanely euthanized and deposited as voucher specimens in the California Academy of Sciences (CAS) and University of Texas at Arlington (UTA) herpetology collections.

We thank M. Edgehouse, A. Mortensen and A. Wilkinson for assistance in the field and R. Lawson for field advice. We are grateful for access to land by the Santa Lucia Preserve. For aid with captive specimens and bioassays we thank A. Mortensen, J. Scoville, A. Wilkinson, J. Pluid, M. Edgehouse, and approval of protocols from USU IACUC. We thank J. Vindum and M. Koo (CAS), and J. Campbell and C. Franklin (UTA) for help with the curation of specimens. For assistance in the laboratory we thank M. Matocq, A. Runck, and M. Andrews and E. O'Leary-Jepsen (ISU MRCF), and K. Kruse and C. Osborne (UNR NGC). We appreciate statistical aid from L. Latta, K. Stewart and P. Murphy, and useful discussions with M. Matocq, E. O'Neill, and the UVA and USU Herp Groups, as well as helpful comments from J. Storz and three anonymous reviewers. For providing scientific collecting permits we thank California Department of Fish and Game. This work was supported by NSF grants to MEP, EDB Jr and EDB III (DEB-0315172, DEB-0922251), a NGS grant (7531-03) to EDB Jr and EDB III, and a USU School of Graduate Studies Dissertation Fellowship to CRF.

REFERENCES

- Abzhanov, A., Protas, M., Grant, B. R., Grant, P. R. & Tabin, C. J. 2004 *Bmp4* and morphological variation of beaks in Darwin's finches. *Science* **305**, 1462–1465. (doi:10.1126/science.1098095)
- Agrawal, A. A. & Lively, C. M. 2002 Infection genetics: gene-for-gene versus matching alleles models and all points in between. *Evol. Ecol. Res.* **4**, 79–90.
- Agrawal, A. A. & Lively, C. M. 2003 Modelling infection as a two-step process combining gene-for-gene and matching-allele genetics. *Proc. R. Soc. Lond. B* **270**, 323–334. (doi:10.1098/rspb.2002.2193)
- Albertson, R. C., Streebman, J. T., Kocher, T. D. & Yelick, P. C. 2005 Integration and evolution of the cichlid mandible: the molecular basis of alternate feeding strategies. *Proc. Natl Acad. Sci. USA* **102**, 16 287–16 292. (doi:10.1073/pnas.0506649102)
- Barrett, R. D. H. & Schluter, D. 2008 Adaptation from standing genetic variation. *Trends Ecol. Evol.* **23**, 38–44. (doi:10.1016/j.tree.2007.09.008)
- Barton, N. H. & Keightley, P. D. 2002 Understanding quantitative genetic variation. *Nat. Rev. Genet.* **3**, 11–21. (doi:10.1038/nrg700)
- Bohannon, B. J. M. & Lenski, R. E. 2000 Linking genetic change to community evolution: insights from studies of bacteria and bacteriophage. *Ecol. Lett.* **3**, 362–377. (doi:10.1046/j.1461-0248.2000.00161.x)
- Brodie Jr, E. D. 1968 Investigations on the skin toxin of the adult rough-skinned newt, *Taricha granulosa*. *Copeia* **1968**, 307–313. (doi:10.2307/1441757)
- Brodie III, E. D. & Brodie Jr, E. D. 1990 Tetrodotoxin resistance in garter snakes: an evolutionary response of predators to dangerous prey. *Evolution* **44**, 651–659.
- Brodie III, E. D. & Brodie Jr, E. D. 1999 Predator–prey arms races: asymmetrical selection on predators and prey may be reduced when prey are dangerous. *Bioscience* **49**, 557–568. (doi:10.2307/1313476)
- Brodie Jr, E. D., Hensel Jr, J. L. & Johnson, J. A. 1974 Toxicity of the urodele amphibians *Taricha Notophthalmus Cynops Paramesotriton* (Salamandridae). *Copeia* **1974**, 506–511. (doi:10.2307/1442542)

- Brodie Jr, E. D., Ridenhour, B. J. & Brodie III, E. D. 2002a The evolutionary response of predators to dangerous prey: hotspots and coldspots in the geographic mosaic of coevolution between garter snakes and newts. *Evolution* **56**, 2067–2082.
- Brodie III, E. D., Brodie Jr, E. D. & Motychak, J. E. 2002b Recovery of garter snakes (*Thamnophis sirtalis*) from the effects of tetrodotoxin. *J. Herpetol.* **36**, 95–98. (doi:10.1670/0022-1511(2002)036[0095:ROGSTS]2.0.CO;2)
- Brodie III, E. D., Feldman, C. R., Hanifin, C. T., Motychak, J. E., Mulcahy, D. G., Williams, B. L. & Brodie Jr, E. D. 2005 Parallel arms races between garter snakes and newts involving tetrodotoxin as the phenotypic interface of coevolution. *J. Chem. Ecol.* **31**, 343–356. (doi:10.1007/s10886-005-1345-x)
- Chen, S.-F., Hartmann, H. A. & Kirsche, G. E. 1997 Cysteine mapping in the ion selectivity and toxin binding region of the cardiac Na⁺ channel pore. *J. Membr. Biol.* **155**, 11–25. (doi:10.1007/s002329900154)
- Choudhary, G., Yotsu-Yamashita, M., Shang, L., Yasumoto, T. & Dudley Jr, S. C. 2003 Interactions of the C-11 hydroxyl of tetrodotoxin with the sodium channel outer vestibule. *Biophys. J.* **84**, 287–294. (doi:10.1016/S0006-3495(03)74849-8)
- Cohn, M. J. & Tickle, C. 1999 Developmental basis of limblessness and axial patterning in snakes. *Nature* **399**, 474–479. (doi:10.1038/20944)
- Colosimo, P. F. *et al.* 2005 Widespread parallel evolution in sticklebacks by repeated fixation of ectodysplasin alleles. *Science* **307**, 1928–1933. (doi:10.1126/science.1107239)
- Du, Y., Nomura, Y., Liu, Z., Huang, Z. Y. & Dong, K. 2009 Functional expression of an arachnid sodium channel reveals residues responsible for tetrodotoxin resistance in invertebrate sodium channels. *J. Biol. Chem.* **284**, 33 869–33 875. (doi:10.1074/jbc.M109.045690)
- Doebly, J. & Stec, A. 1991 Genetic analysis of the morphological differences between maize and teosinte. *Genetics* **129**, 285–295.
- Falconer, D. S. & Mackay, T. F. C. 1996 *Introduction to quantitative genetics*. Harlow, UK: Addison-Wesley Logman.
- Feldman, C. R., Brodie Jr, E. D., Brodie III, E. D. & Pfrender, M. E. 2009 The evolutionary origins of beneficial alleles during the repeated adaptation of garter snakes (*Thamnophis*) to deadly prey. *Proc. Natl Acad. Sci. USA* **106**, 13 415–13 420. (doi:10.1073/pnas.0901224106)
- Ffrench-Constant, R. H., Daborn, P. J. & Le Goff, G. 2004 The genetics and genomics of insecticide resistance. *Trends Genet.* **20**, 163–170. (doi:10.1016/j.tig.2004.01.003)
- Fisher, R. A. 1958 *The genetical theory of natural selection*. New York, NY: Dover Publications.
- Futuyma, D. J. 1998 *Evolutionary biology*. Sunderland, MA: Sinauer Associates.
- Garner, T. W. J., Gregory, P. T., McCracken, G. F., Burghardt, G. M., Koop, B. F., McLain, S. E. & Nelson, R. J. 2002 Geographic variation of multiple paternity in the common garter snake (*Thamnophis sirtalis*). *Copeia* **2002**, 15–23. (doi:10.1643/0045-8511(2002)002[0015:GVOMPI]2.0.CO;2)
- Garner, T. W. J., Pearman, P. B., Gregory, P. G., Tomio, G., Wischniowski, S. G. & Hosken, D. J. 2004 Microsatellite markers developed from *Thamnophis elegans* and *Thamnophis sirtalis* and their utility in three species of garter snakes. *Mol. Ecol. Notes* **4**, 369–371. (doi:10.1111/j.1471-8286.2004.00656.x)
- Geffeney, S. L., Brodie Jr, E. D., Ruben, P. C. & Brodie III, E. D. 2002 Mechanisms of adaptation in a predator–prey arms race: TTX-resistant sodium channels. *Science* **297**, 1336–1339. (doi:10.1126/science.1074310)
- Geffeney, S. L., Fujimoto, E., Brodie III, E. D., Brodie Jr, E. D. & Ruben, P. C. 2005 Evolutionary diversification of TTX-resistant sodium channels in a predator–prey interaction. *Nature* **434**, 759–763. (doi:10.1038/nature03444)
- Goldin, A. L. 2001 Resurgence of sodium channel research. *Annu. Rev. Physiol.* **63**, 871–894. (doi:10.1146/annurev.physiol.63.1.871)
- Goldin, A. L. 2002 Evolution of voltage-gated Na⁺ channels. *J. Exp. Biol.* **205**, 575–584.
- Hanifin, C. T., Brodie Jr, E. D. & Brodie III, E. D. 2008 Phenotypic mismatches reveal escape from arms-race coevolution. *Public Libr. Sci. Biol.* **6**, e60.
- Hartley, C. J., Newcomb, R. D., Russell, R. J., Yong, C. G., Stevens, J. R., Yeates, D. K., La Salle, J. & Oakeshott, J. G. 2006 Amplification of DNA from preserved specimens shows blowflies were preadapted for the rapid evolution of insecticide resistance. *Proc. Natl Acad. Sci. USA* **103**, 8757–8762. (doi:10.1073/pnas.0509590103)
- Hawthorne, D. J. & Via, S. 2001 Genetic linkage of ecological specialization and reproductive isolation in pea aphids. *Nature* **412**, 904–907. (doi:10.1038/35091062)
- Hille, B. 2001 *Ion channels of excitable membranes*. Sunderland, MA: Sinauer Associates.
- Hoekstra, H. E., Hirschmann, R. J., Bunday, R. A., Insel, P. A. & Crossland, J. P. 2006 A single amino acid mutation contributes to adaptive beach mouse color pattern. *Science* **313**, 101–107. (doi:10.1126/science.1126121)
- How, C. K., Chern, C. H., Huang, Y. C., Wang, L. M. & Lee, C. H. 2003 Tetrodotoxin poisoning. *Am. J. Emerg. Med.* **21**, 51–54. (doi:10.1053/ajem.2003.50008)
- Isbister, G. K. & Kiernan, M. C. 2005 Neurotoxic marine poisoning. *Lancet Neurol.* **4**, 219–228. (doi:10.1016/S1474-4422(05)70041-7)
- Joron, M. *et al.* 2006 A conserved supergene locus controls colour pattern diversity in *Heliconius* butterflies. *Public Libr. Sci. ONE* **4**, e303.
- Jost, M. C., Hillis, D. M., Lu, Y., Kyle, J. W., Fozzard, H. A. & Zakon, H. H. 2008 Toxin-resistant sodium channels: parallel adaptive evolution across a complete gene family. *Mol. Biol. Evol.* **25**, 1016–1024. (doi:10.1093/molbev/msn025)
- Kao, C. Y. & Levinson, S. R. 1986 *Tetrodotoxin, saxitoxin, and the molecular biology of the sodium channel*. Annals of the New York Academy of Sciences. New York, NY: New York Academy of Sciences.
- Kimura, M. 1983 *The neutral theory of molecular evolution*. Cambridge, UK: Cambridge University Press.
- Kopp, M. & Gavrillets, S. 2006 Multilocus genetics and the coevolution of quantitative traits. *Evolution* **60**, 1321–1336.
- Krieger, M. J. B. & Ross, K. G. 2002 Identification of a major gene regulating complex social behavior. *Science* **295**, 328–332. (doi:10.1126/science.1065247)
- Lai, J., Hunter, J. C. & Porreca, F. 2003 The role of voltage-gated sodium channels in neuropathic pain. *Curr. Opin. Neurobiol.* **13**, 291–297. (doi:10.1016/S0959-4388(03)00074-6)
- Lande, R. 1983 The response to selection on major and minor mutations affecting a metrical trait. *Heredity* **50**, 47–66. (doi:10.1038/hdy.1983.6)
- Lipkind, G. M. & Fozzard, H. A. 2000 KcsA crystal structure as framework for a molecular model of the Na⁺ channel pore. *Biochemistry* **39**, 8161–8170. (doi:10.1021/bi000486w)
- Maddison, D. R. & Maddison, W. P. 2005 *MACCLADE: analysis of phylogeny and character evolution*. Sunderland, MA: Sinauer Associates.
- Manier, M. K. & Arnold, S. J. 2005 Population genetic analysis identifies source-sink dynamics for two sympatric garter snake species (*Thamnophis elegans* and *Thamnophis*

- sirtalis*). *Mol. Ecol.* **14**, 3965–3976. (doi:10.1111/j.1365-294X.2005.02734.x)
- Maruta, S., Yamaokab, K. & Yotsu-Yamashita, M. 2008 Two critical residues in p-loop regions of puffer fish Na⁺ channels on TTX sensitivity. *Toxicon* **51**, 381–387. (doi:10.1016/j.toxicon.2007.10.014)
- McCracken, G. F., Burghardt, G. M. & Houts, S. E. 1999 Microsatellite markers and multiple paternity in the garter snake *Thamnophis sirtalis*. *Mol. Ecol.* **8**, 1475–1479. (doi:10.1046/j.1365-294x.1999.00720.x)
- Medinsky, M. A. & Klaassen, C. D. 1996 Toxicokinetics. In *Casarett and Doull's toxicology: the basic science of poisons* (ed. C. D. Klaassen), pp. 187–198. New York, NY: McGraw-Hill.
- Mosher, H. S., Fuhrman, F. A., Buchwald, H. D. & Fischer, H. G. 1964 Tarichatoxin-tetrodotoxin: a potent neurotoxin. *Science* **144**, 1100–1110. (doi:10.1126/science.144.3622.1100)
- Motychak, J. E., Brodie Jr, E. D. & Brodie III, E. D. 1999 Evolutionary response of predators to dangerous prey: preadaptation and the evolution of tetrodotoxin resistance in garter snakes. *Evolution* **53**, 1528–1535. (doi:10.2307/2640898)
- Noda, M., Suzuki, H., Numa, S. & Stuhmer, W. 1989 A single point mutation confers tetrodotoxin and saxitoxin insensitivity on the sodium channel II. *FEBS Lett.* **259**, 213–216. (doi:10.1016/0014-5793(89)81531-5)
- Novak, A. E., Jost, M. C., Lu, Y., Taylor, A. D., Zakon, H. H. & Ribera, A. B. 2006 Gene duplications and evolution of vertebrate voltage-gated sodium channels. *J. Mol. Evol.* **63**, 208–221. (doi:10.1007/s00239-005-0287-9)
- Nuismer, S. L., Ridenhour, B. J. & Oswald, B. P. 2007 Antagonistic coevolution mediated by phenotypic differences between quantitative traits. *Evolution* **61**, 1823–1834. (doi:10.1111/j.1558-5646.2007.00158.x)
- Orr, H. A. 2005 The genetical theory of adaptation: a brief history. *Nat. Rev. Genet.* **6**, 119–127. (doi:10.1038/nrg1523)
- Orr, H. A. & Coyne, J. A. 1992 The genetics of adaptation: a reassessment. *Am. Nat.* **140**, 724–742.
- Peakall, R. & Smouse, P. E. 2006 GENALEX 6: genetic analysis in Excel. Population genetic software for teaching and research. *Mol. Ecol. Notes* **6**, 288–295. (doi:10.1111/j.1471-8286.2005.01155.x)
- Penzotti, J. L., Fozzard, H. A., Lipkind, G. M. & Dudley Jr, S. C. 1998 Differences in saxitoxin and tetrodotoxin binding revealed by mutagenesis of the Na⁺ channel outer vestibule. *Biophys. J.* **75**, 2647–2657. (doi:10.1016/S0006-3495(98)77710-0)
- Pérez-García, M. T., Chiamvimonvat, N., Marban, E. & Tomaselli, G. F. 1996 Structure of the sodium channel pore revealed by serial cysteine mutagenesis. *Proc. Natl Acad. Sci. USA* **93**, 300–304. (doi:10.1073/pnas.93.1.300)
- Plummer, N. W. & Meisler, M. H. 1999 Evolution and diversity of mammalian sodium channel genes. *Genomics* **57**, 323–331. (doi:10.1006/geno.1998.5735)
- Prosser, M. R., Gibbs, H. L. & Weatherhead, P. J. 1999 Microgeographic population genetic structure in the northern watersnake, *Nerodia sipedon sipedon* detected using microsatellite DNA loci. *Mol. Ecol.* **8**, 329–333. (doi:10.1046/j.1365-294X.1999.00530.x)
- Raymond, M. & Rousset, F. 1995 GENEPOP, version 1.2: population genetics software for exact tests and ecumenicism. *J. Hered.* **86**, 248–249.
- Rice, W. R. 1989 Analyzing tables of statistical tests. *Evolution* **43**, 223–225. (doi:10.2307/2409177)
- Ridenhour, B. J., Brodie III, E. D. & Brodie Jr, E. D. 2004 Resistance of neonates and field-collected garter snakes (*Thamnophis* spp.) to tetrodotoxin. *J. Chem. Ecol.* **30**, 143–154. (doi:10.1023/B:JOEC.0000013187.79068.d2)
- Ridenhour, B. J., Brodie Jr, E. D. & Brodie III, E. D. 2007 Patterns of genetic differentiation in *Thamnophis* and *Taricha* from the Pacific Northwest. *J. Biogeogr.* **34**, 724–735. (doi:10.1111/j.1365-2699.2006.01642.x)
- Rousset, F. 2008 GENEPOP'007: a complete re-implementation of the GENEPOP software for Windows and Linux. *Mol. Ecol. Resour.* **8**, 103–106. (doi:10.1111/j.1471-8286.2007.01931.x)
- Sasaki, A. 2000 Host–parasite coevolution in a multilocus gene-for-gene system. *Proc. R. Soc. Biol. Sci. Ser. B* **267**, 2183–2188. (doi:10.1098/rspb.2000.1267)
- Scheib, H., McLay, I., Guex, N., Clare, J. J., Blaney, F. E., Dale, T. J., Tate, S. N. & Robertson, G. M. 2006 Modeling the pore structure of voltage-gated sodium channels in closed, open, and fast-inactivated conformation reveals details of site 1 toxin and local anesthetic binding. *J. Mol. Model.* **12**, 813–822. (doi:10.1007/s00894-005-0066-y)
- Storz, J. F., Sabatino, S. J., Hoffmann, F. G., Gering, E. J., Moriyama, H., Ferrand, N., Monteiro, B. & Nachman, M. W. 2007 The molecular basis of high-altitude adaptation in deer mice. *Public Libr. Sci. Genet.* **3**, e45.
- Storz, J. F., Runck, A. M., Sabatino, S. J., Kelly, J. K., Ferrand, N., Moriyama, H., Weber, R. E. & Fago, A. 2009 Evolutionary and functional insights into the mechanism underlying high altitude adaptation of deer mouse hemoglobin. *Proc. Natl Acad. Sci. USA* **106**, 14450–14455. (doi:10.1073/pnas.0905224106)
- Sutter, N. B. *et al.* 2007 A single IGF1 allele is a major determinant of small size in dogs. *Science* **316**, 112–115. (doi:10.1126/science.1137045)
- Terlau, H., Heinemann, S. H., Stuhmer, W., Pusch, M., Conti, F., Imoto, K. & Numa, S. 1991 Mapping the site of block by tetrodotoxin and saxitoxin of sodium channel II. *FEBS Lett.* **293**, 93–96. (doi:10.1016/0014-5793(91)81159-6)
- Thompson, J. N. 2005 *The geographic mosaic of coevolution*. Chicago, IL: University of Chicago Press.
- Tikhonov, D. B. & Zhorov, B. S. 2005 Modeling P-Loops domain of sodium channel: homology with potassium channels and interaction with ligands. *Biophys. J.* **88**, 184–197. (doi:10.1529/biophysj.104.048173)
- Trimmer, J. S. *et al.* 1989 Primary structure and functional expression of a mammalian skeletal muscle sodium channel. *Neuron* **3**, 33–49. (doi:10.1016/0896-6273(89)90113-X)
- Trimmer, J. S., Cooperman, S. S., Agnew, W. S. & Mandel, G. 1990 Regulation of muscle sodium channel transcripts during development and in response to denervation. *Dev. Biol.* **142**, 360–367. (doi:10.1016/0012-1606(90)90356-N)
- Venkatesh, B., Lu, S. Q., Dandona, N., See, S. L., Brenner, S. & Soong, T. W. 2005 Genetic basis of tetrodotoxin resistance in pufferfishes. *Curr. Biol.* **15**, 2069–2072. (doi:10.1016/j.cub.2005.10.068)
- Wade, M. J. 2007 The co-evolutionary genetics of ecological communities. *Nat. Rev. Genet.* **8**, 185–195. (doi:10.1038/nrg2031)
- Wakely, J. F., Fuhrman, G. J., Fuhrman, F. A., Fischer, H. G. & Mosher, H. S. 1966 The occurrence of tetrodotoxin (tarichatoxin) in amphibia and the distribution of the toxin in the organs of the newts (*Taricha*). *Toxicon* **3**, 195–203. (doi:10.1016/0041-0101(66)90021-3)
- Yoshida, T., Ellner, S. P., Jones, L. E., Bohannan, B. J. M., Lenski, R. E. & Hairston, N. G. 2007 Cryptic population dynamics: rapid evolution masks trophic interactions. *Public Libr. Sci. Biol.* **5**, e235.
- Yotsu, M., Iorizzi, M. & Yasumoto, T. 1990 Distribution of tetrodotoxin, 6-epitetrodotoxin, and 11-deoxytetrodotoxin in newts. *Toxicon* **28**, 238–241. (doi:10.1016/0041-0101(90)90419-8)